

**The George Washington University  
School of Engineering and Applied Science  
Department of Electrical and Computer Engineering  
ECE 20 – SPICE Tutorial 5**

*Designing a Common-Emitter Amplifier*

*Background:*

There are 2 popular types of Common-Emitter amplifiers:

1. Common-Emitter Amplifier without emitter degeneration (Fig 1.1)
  - sometimes called: *grounded emitter*, or simply: *common-emitter*
  - This is the type you built in lab 5
2. Common-Emitter Amplifier with emitter degeneration (Fig 1.2)
  - sometimes called: **common-emitter with emitter resistor**
  - There are 3 configurations of this circuit possible:
    - a. Non bypassed emitter resistor
    - b. Bypassed emitter resistor with a series external emitter resistor
    - c. Bypassed emitter resistor with a parallel external emitter resistor

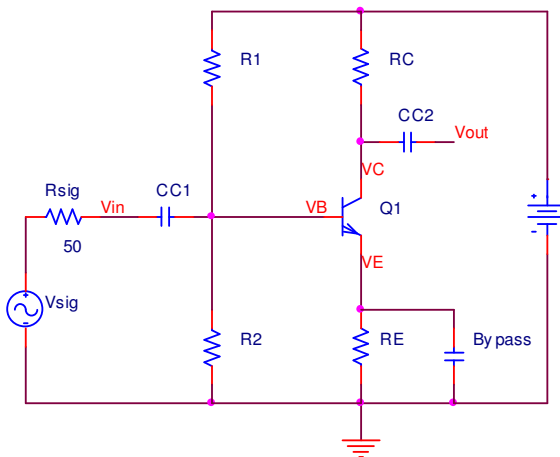

**Fig 1.1** - C.E. without emitter degeneration

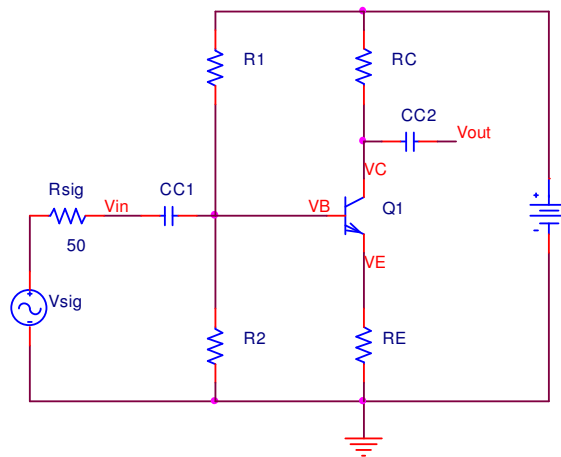

**Fig 1.2** - C.E. with emitter degeneration (no bypass cap)

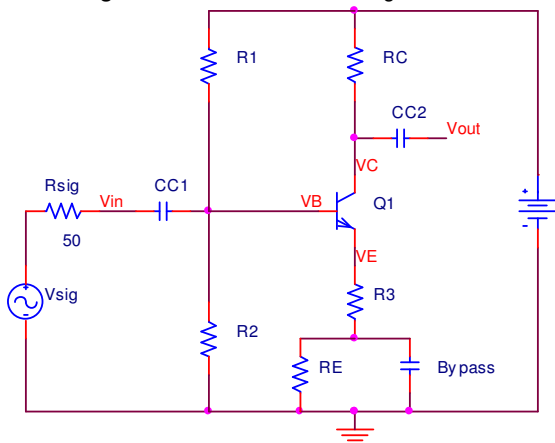

**Fig 1.3** - C.E. with emitter degeneration series resistor

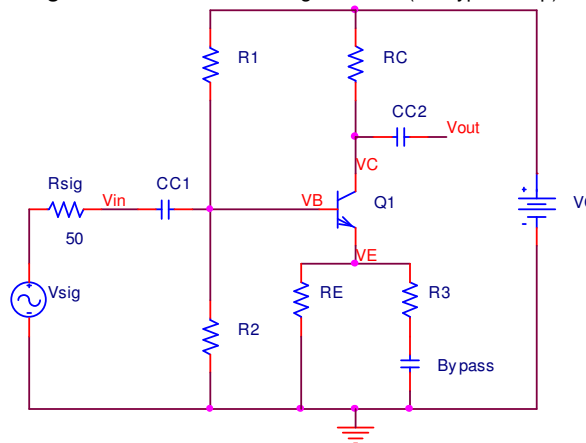

**Fig 1.4** - C.E. with emitter degeneration parallel resistor

The 2 forms of the common-emitter amplifier and their various configurations have own advantages and disadvantages when compared to one another. From the perspective of this tutorial, we will concentrate on the way 'gain' is controlled for each of the circuits. But, no matter the configuration, for any common-emitter amplifier, **the input signal is always through the base terminal, the output is always take from the collector terminal, and the emitter is always 'common' to both the input and output.**

For type 1 (C-E without emitter degeneration), from figure 1.1 the 'bypass' capacitor shorts the **emitter to ground** for high frequency signals; hence the name 'grounded emitter.' This amplifier is discussed in Sedra p 467-470. The voltage gain of this amplifier (when no load is present) is  $A_v = -g_m RC$ . The designer can only control the value of RC (and to some extent  $g_m$ ) to control the voltage gain of the amplifier. This is the type you built in lab 5 during the common-emitter portion of the lab.

For type 2a (C-E with emitter degeneration – non-bypassed emitter resistor), shown in figure 1.2 there is no 'bypass' capacitor. The emitter terminal is 'common' to both the input and output through the resistor connected to the emitter (RE). The emitter resistor (RE) serves to give bias stability to the circuit. This amplifier is discussed in Sedra p 470-474. The gain of this amplifier (when no load is present) is  $A_v = -\alpha RC / (r_e + RE)$  or more simply:  $A_v \approx -RC / (r_e + RE)$ . The designer can now use RC and RE to control the voltage gain of the amplifier.

For type 2b (C-E with emitter degeneration – bypassed emitter resistor with series emitter resistor-R3), shown in figure 1.3 the 'bypass' capacitor shorts the resistor R3 to ground for high frequency signals. The emitter terminal is 'common' to both the input and output through the resistor (R3). The emitter resistor (R3) serves to give bias stability to the circuit. This amplifier is not discussed in Sedra. The gain of this amplifier (when no load is present) is  $A_v \approx -RC / (r_e + R3)$ . The designer typically leaves RC and uses R3 to control the voltage gain of the amplifier.

For type 2c (C-E with emitter degeneration – bypassed emitter resistor with parallel emitter resistor-R3), shown in figure 1.4 the 'bypass' capacitor shorts the resistor R3 to ground for high frequency signals. Typically R3 is much smaller than RE, making it so RE is 'bypassed' by comparison to R3. R3 is an easier 'path to ground' than for AC signals. The emitter terminal is 'common' to both the input and output through the resistor (R3). This amplifier is not discussed in Sedra. The gain of this amplifier (when no load is present) is  $A_v \approx -RC / (r_e + R3)$ . The designer typically leaves RC and uses R3 to control the voltage gain of the amplifier. The advantage of this design is that R3 serves no purpose in the 'DC biasing' of the amplifier. So the designer only sets the value of R3 after the 'DC bias' has been determined for the amplifier.

The student is encouraged to use any of the common-emitter amplifier configurations show above in labs and projects. Because type 2 is stable, is the easiest to 'bias,' and then to tailor the 'gain' without affecting its DC bias, it will be covered in this tutorial.

*Designing a Common-Emitter Amplifier w/ emitter degeneration through a parallel emitter resistor*

Problem: Design a Common-Emitter Amplifier using the 2N3904 transistor that meets the following specifications:

$$\begin{aligned} I_C &= 2\text{mA} \\ V_{CC} &= 30\text{ Volts} \\ A_v \text{ (without load)} &= -50 \\ R_{in} \text{ (DC)} &= 4\text{K}\Omega \\ R_L &= 1\text{K}\Omega \\ v_{in} &= 10\text{mV @ } 10\text{kHz} \end{aligned}$$

Step 1) Begin with the skeleton of the amplifier we'd like to design, figure 2.1:

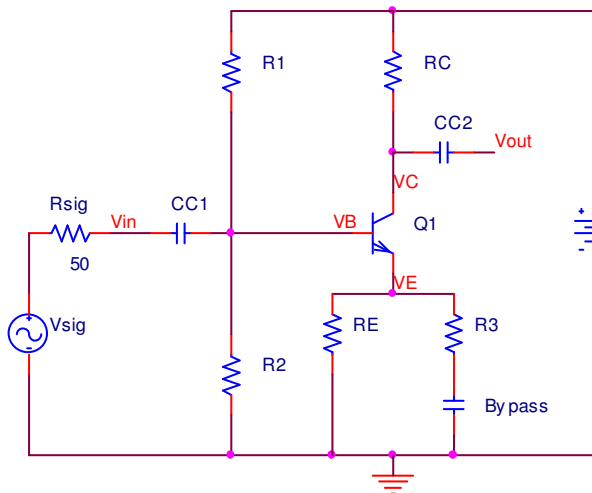

**Fig 2.1** – Complete Common-Emitter Amplifier

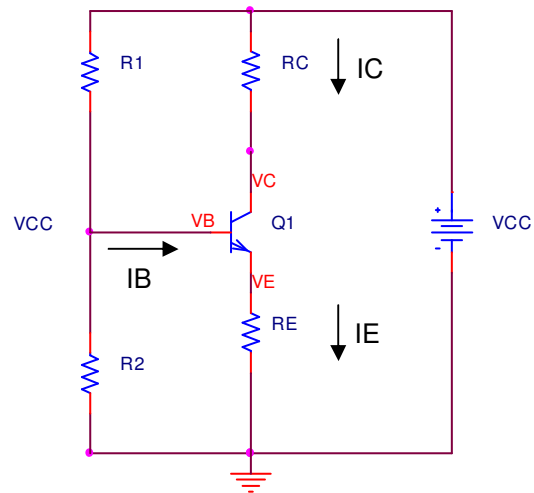

**Fig 2.2** – C.E Amplifier (DC only)

- Our goal as designers will be to determine values for  $R_C$ ,  $R_E$ ,  $R_1$ ,  $R_2$ ,  $R_3$ ,  $CC_1$ ,  $CC_2$ , and the Bypass Cap based on the specs given. We begin by determining the values of  $R_C$ ,  $R_E$ ,  $R_1$ , and  $R_2$  to provide DC bias to the transistor. Then we view the circuit from an 'AC' perspective to determine the size of  $R_3$  to set the 'gain' for the amplifier.
- From a DC perspective, the amplifier looks like the circuit in figure 2.2. This is because the impedance of the  $CC_1$ ,  $CC_2$ , and Bypass capacitor at DC ( $\approx 0$  Hz), is nearly 'infinite.' So the capacitor's look like 'open' circuits at DC. This is why  $R_3$  disappears from the circuit.
- Fig 2.2 looks just like what we did in Lab 5, except we're solving the problem in reverse.

Step 2) Determine the value of RC

- Because we take the 'output' voltage from VC, we start with the equation for VC:
- Due to the equation:  $VC = VCC - IC * RC$  (which is just Ohm's law for the voltage across RC),
- The maximum output voltage we can have when  $IC = 0mA$ , is 30Volts (VCC). The minimum output voltage we can have when  $IC$  is at its highest, which makes  $VC = 0$  Volts. We want the 'AC' signal that comes out to 'swing' symmetrically around the mid-point ( $\frac{1}{2} VCC$ ).

We set  $VC = \frac{1}{2} (VCC) = 15V$

- Since  $IC$  is given at 2mA, we can use Ohm's Law, to determine RC:

$$RC = \frac{(VCC - VC)}{IC} = \frac{(30 - 15)}{2mA} = 7.5K\Omega$$

Step 3) Determine the "Q" point of the transistor

- From the test bench we created in lab 4 to characterize the 2N3904 transistor, we perform a parametric sweep simulation to obtain the IV curve for the transistor. We sweep VCE from 0 to VCC (30V). I have swept current  $IB$  from 0 to 20uA, in steps of 2.3uA. I used trial and error until I was able to get a curve to tell me what  $IB$  was, when  $IC=2mA$ .

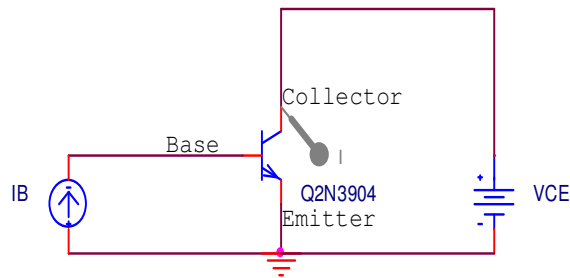
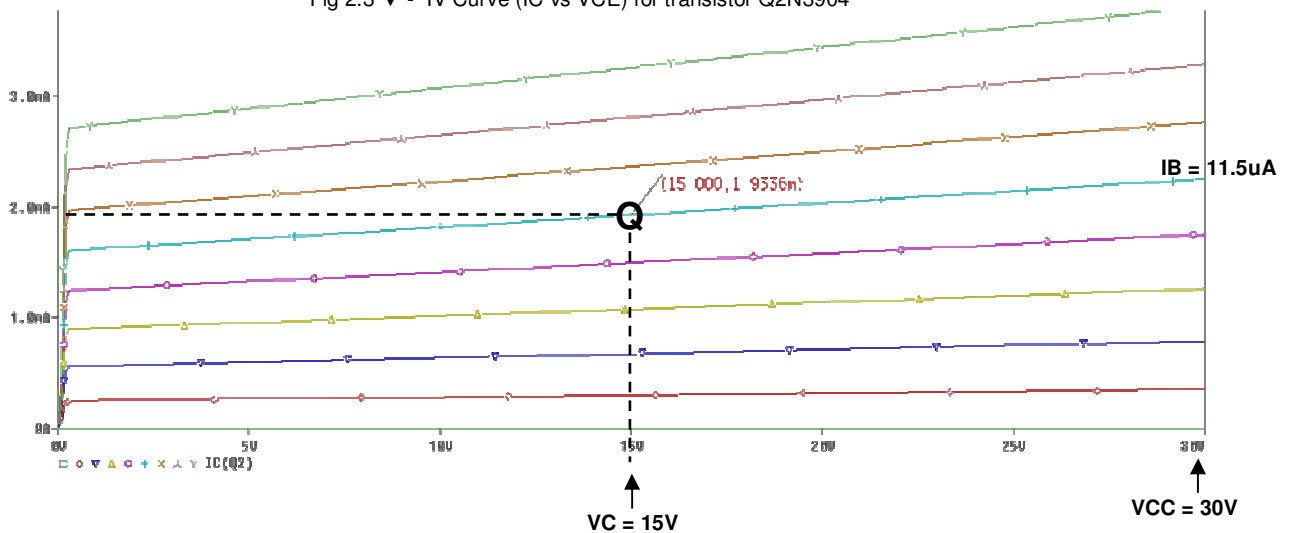

Fig 2.3 ▼ - IV Curve ( $IC$  vs  $VCE$ ) for transistor Q2N3904



- In the spec, we were told  $I_C = 2\text{mA}$ . We determine that  $V_C = 15\text{V}$  in the last step. That is our 'quiescent value' or Q value. From the IV-Curve, we can see that the 2N3904 transistor will supply  $\sim 2\text{mA}$  of current when the base current is set to  $I_B = 11.5\mu\text{A}$ . With this information, we can determine  $I_E$ ,  $R_1$ ,  $R_2$ , and  $R_E$ . So far we know:

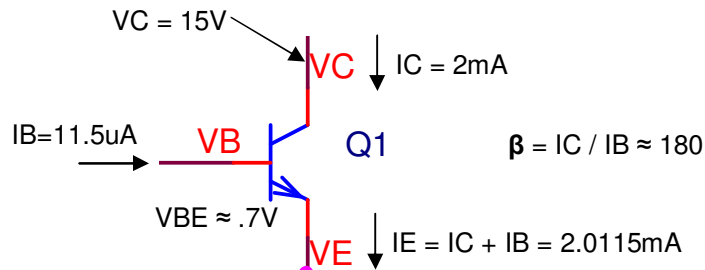

Fig 2.4 – DC Bias State for the 2N3904

Step 4) Find  $R_E$ ,  $V_E$ ,  $V_B$ :

- For this type of common-emitter amplifier, as a rule of thumb, we choose  $R_E$  to be 10% of  $R_C$   
 $R_E = 10\% R_C = (.1 * 7.5\text{K}\Omega) = 750\ \Omega$
- From Ohm's Law, we can find  $V_E$ :  
 $V_E = I_E * R_E = 2.0115\text{mA} * 750\ \Omega \approx 1.5\text{V}$   
 $V_B = V_E + V_{BE} = 1.5 + .7\text{V} = 2.2\text{V}$

Step 5) Use  $V_{CC}$ ,  $V_B$ ,  $I_B$  &  $R_{IN}$  (DC), to find  $R_1$  &  $R_2$ :

- Our goal is to deliver  $11.5\mu\text{A}$  to the base of the transistor
- $R_1$  &  $R_2$  must be properly sized to achieve this goal
- We generate 3 equations to find  $R_1$  &  $R_2$
- Since  $R_1$  &  $R_2$  are in parallel (as we learned from lab 5's tutorial), we know:

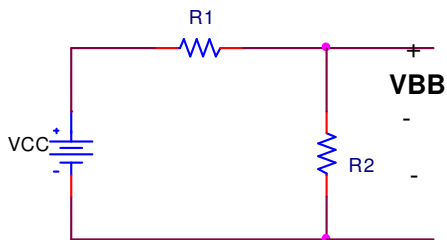

The Thevenin Voltage ( $V_{BB}$ ) is:

Eqn 1:  $V_{BB} = V_{CC} \left( \frac{R_2}{R_1 + R_2} \right)$

The Thevenin Resistance ( $R_B$ ) is:

Eqn 2:  $R_B = R_1 \parallel R_2$

- Using the Thevenin equivalent resistance ( $R_B$ ) for  $R_1$  &  $R_2$  (as we did in lab 5), we know our circuit can be redrawn to look like this:

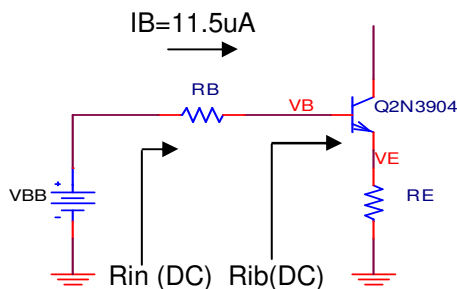

Using Ohm's Law, we generate eqn 3:

$$\left( \frac{V_{BB} - V_B}{R_B} \right) = I_B$$

Eqn 3:  $V_{BB} = I_B * R_B + V_B$

- In equations 1-3, we know VCC, IB, and VB. But we do not know R1, R2, RB, or VBB. That's 4 unknowns, but only 3 equations, we need to find one of these variable's value to solve them all. We can use the spec value for Rin(DC) to find the value of RB.
- From the Thevenin equivalent figure above, we can see that:

$$\text{Eqn 4: } R_{in}(DC) = R_B \parallel R_{ib}(DC)$$

- Rib(DC) is the input resistance looking into the 'base' of the transistor. Since only RE is attached to the emitter at DC (because R3 + C bypass appears as an infinite load at DC), we can use the value found in Sedra (in the common-emitter with emitter resistance section - p 472) for Rib:

$$R_{ib} = (\beta + 1) (r_e + R_E)$$

We know from Sedra (p459), that:

$$r_e = V_T / I_E = .026V / 2.0015mA \approx 13\Omega$$

This makes Rib  $\approx 138\Omega$

- Using Rib, and Rin, from equation 4, we can solve for RB:

$$R_B = \left( \frac{R_{in}(DC) * R_{ib}(DC)}{R_{ib}(DC) - R_{in}(DC)} \right) \approx 4K\Omega$$

- With RB found, we can use **equations 1, 2, and 3** (+ some Algebra) to find R1 & R2:

$$R_1 \approx 53K\Omega$$

$$R_2 \approx 4K\Omega$$

- All the 'biasing' resistors, currents, and voltages have now been found!

*Step 6) Use R3 to set the gain for the CE amplifier*

- The gain for this type of common-emitter amplifier is (with no load attached):

$$A_v(\text{unloaded}) = - \left( \frac{R_C}{r_e + R_3} \right)$$

- The spec requires Av (unloaded) to be equal to -50, which makes R3:

$$R_3 = \left( \frac{R_C}{A_v(\text{unloaded})} \right) - r_e = 137\Omega$$

*Step 7) Determine the gain when load is attached:*

- The gain for this type of common-emitter amplifier (with a load attached) is:

$$A_v(\text{w/ load}) = - \left( \frac{R_C \parallel R_L}{r_e + R_3} \right) \approx -6$$

*Step 8) Set values for CC1, CC2, CB1:*

- The impedance of a capacitor  $Z_c = 1/j2\pi fC$ , make CC1, CC2, & CB1 to look like a 'short' at 10kHz (the input frequency), and match a value found in your ECE 20 kit.